

600 SERIES

USE & CARE GUIDE





600  SERIES

INTRODUCING THE 600 SERIES

Creative Solutions to Your Home Food Needs

Thank you for purchasing your new Sub-Zero 600 Series unit. With Sub-Zero, you can rely on a 50 year tradition of quality and reliability. The 600 Series brings together the latest and finest features in home refrigeration to give you the freshest, best tasting food in the world.

Your Sub-Zero 600 Series unit is protected by a warranty that is one of the finest in the industry. Take a moment to read the warranty statement at the rear of this book, and refer to it should service become necessary.

This Use and Care Guide will answer most of your questions about the features, operation and maintenance of your 600 Series unit. If you have questions that are not addressed here, call 800-222-7820.

Table of Contents

<i>Introducing the 600 Series</i>	3
<i>600 Series Models</i>	
Models 601R and 601F . . .	4
Models 611 and 650	5
Models 642 and 632	6
Models 680 and 690	7
Model 561	8
<i>Features of the 600 Series</i>	9-10
<i>Using Your Sub-Zero</i>	
The Electronic Control System	11-12
Refrigerator Storage	12-13
Freezer Storage	14-15
Models 680 and 690 Ice and Water Through the Door	16-17
Operations	18
<i>Caring For Your Sub-Zero</i>	
Cleaning	19-20
Lighting Information	20-21
Vacation Time	21
<i>Troubleshooting Guide</i>	22-23
<i>Keeping Food at its Best</i>	
Keeping Food Fresh	24
Keeping Food Safe to Eat	25-27
Food Storage Suggestions	28-33
<i>Service Information</i>	34

600 SERIES MODELS

Model 601R
All Refrigerator

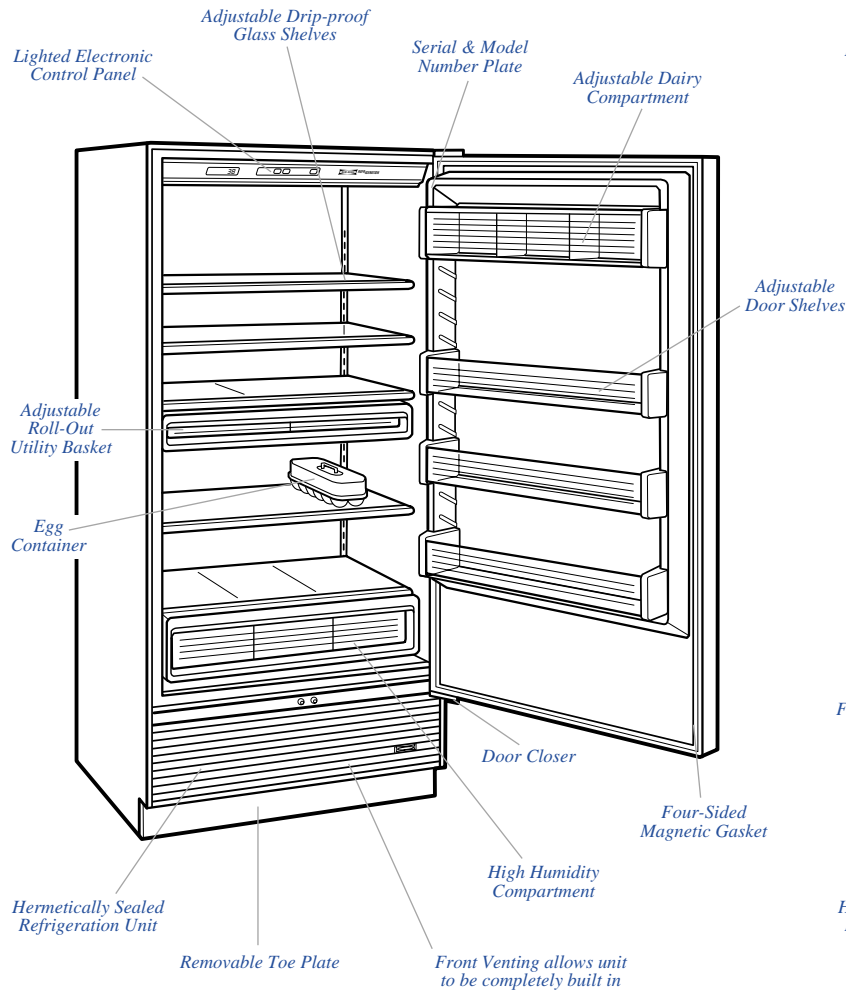

Model 601F
All Freezer

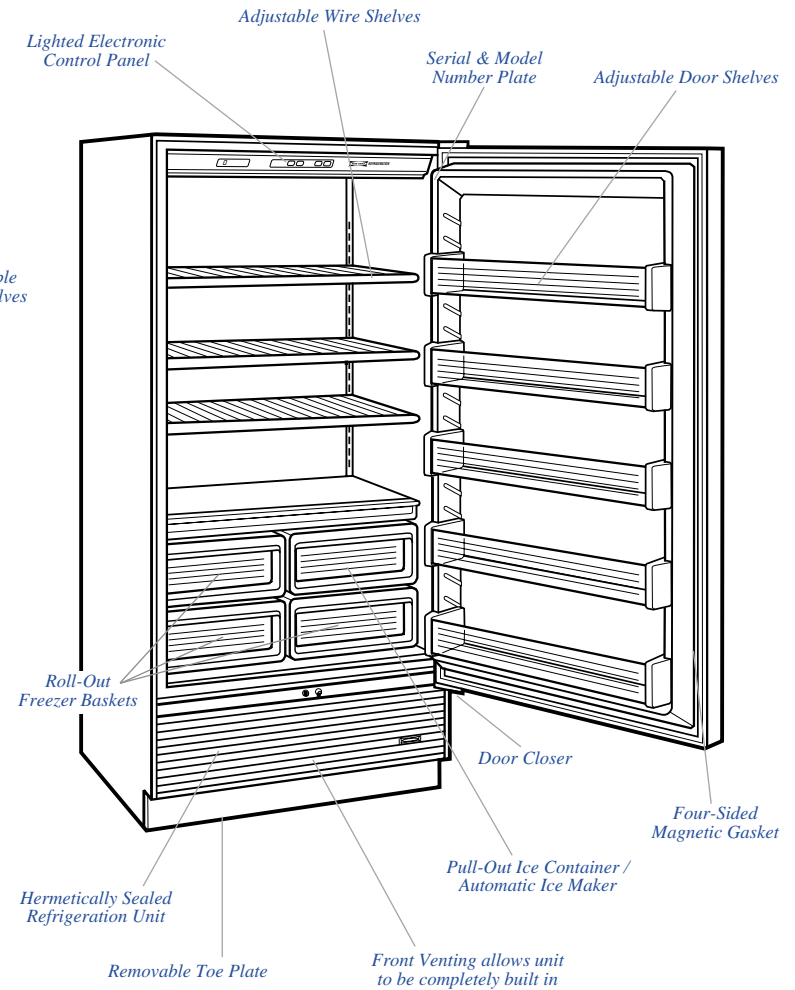

Model 611
Combination Unit

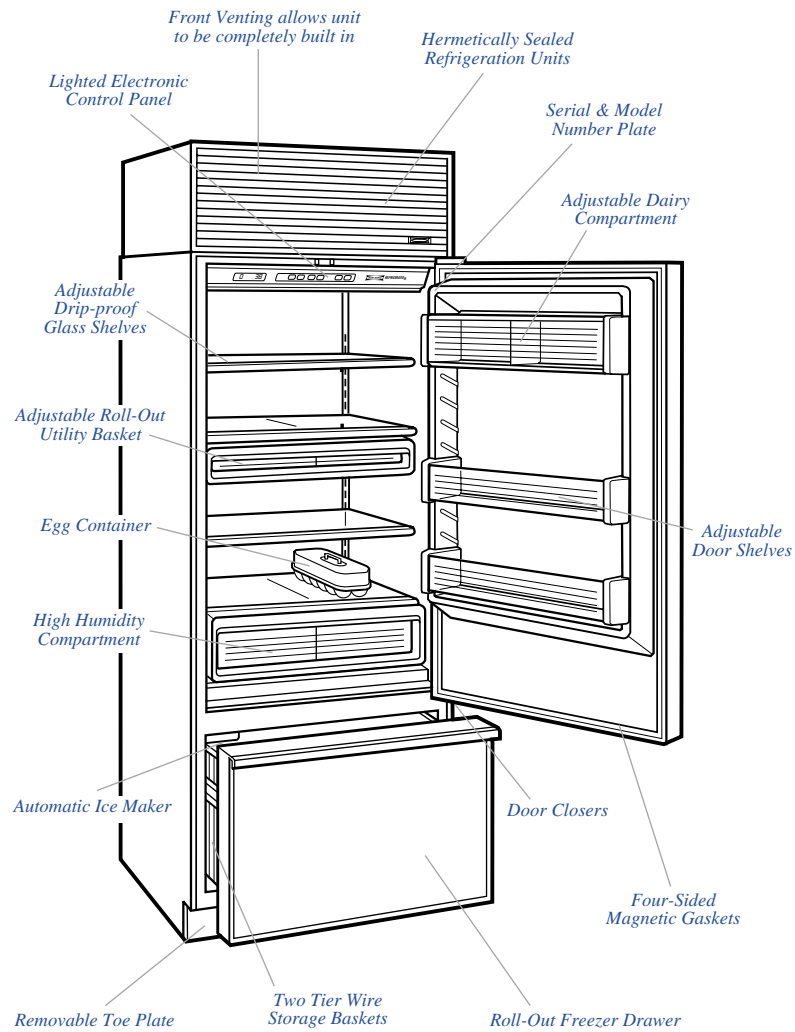

Model 650
Combination Unit

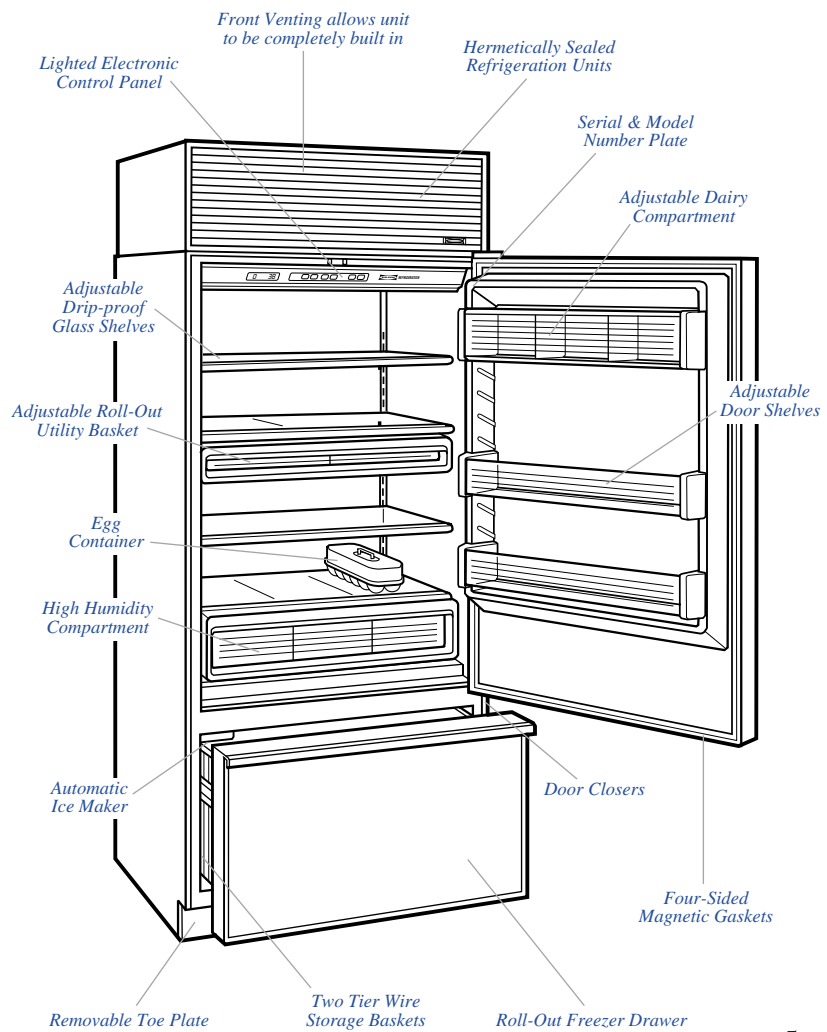

600 SERIES MODELS

Model 642
Combination Unit

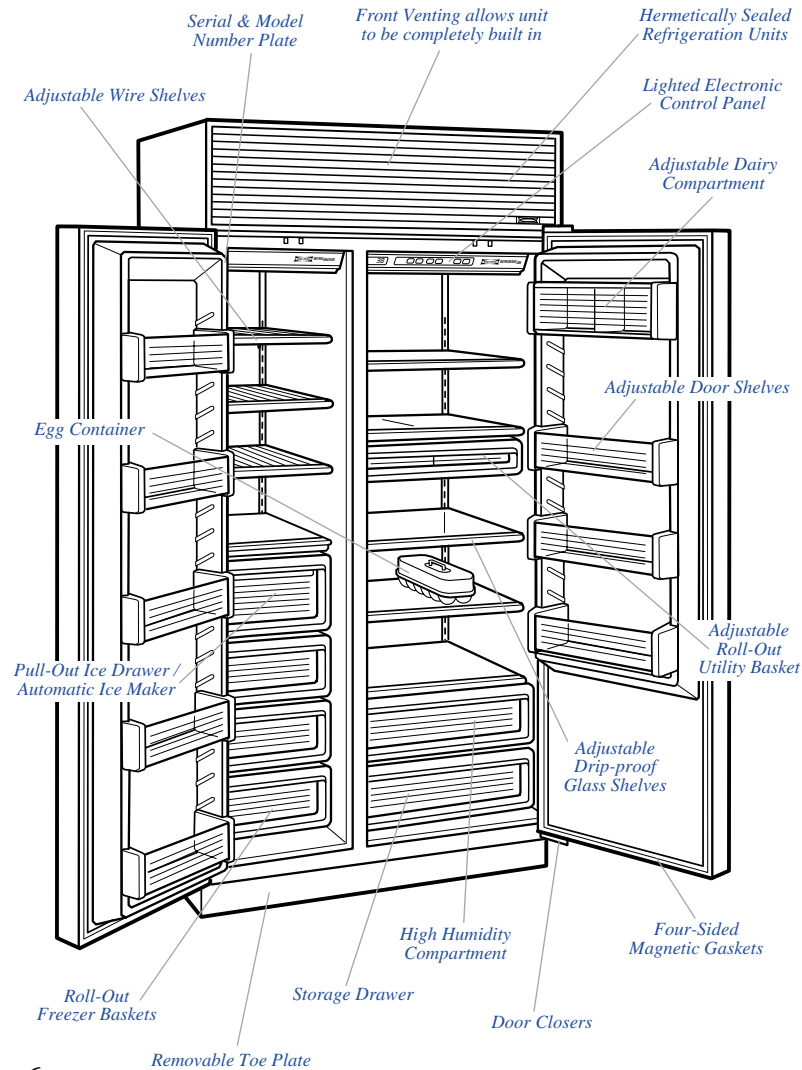

Model 632
Combination Unit

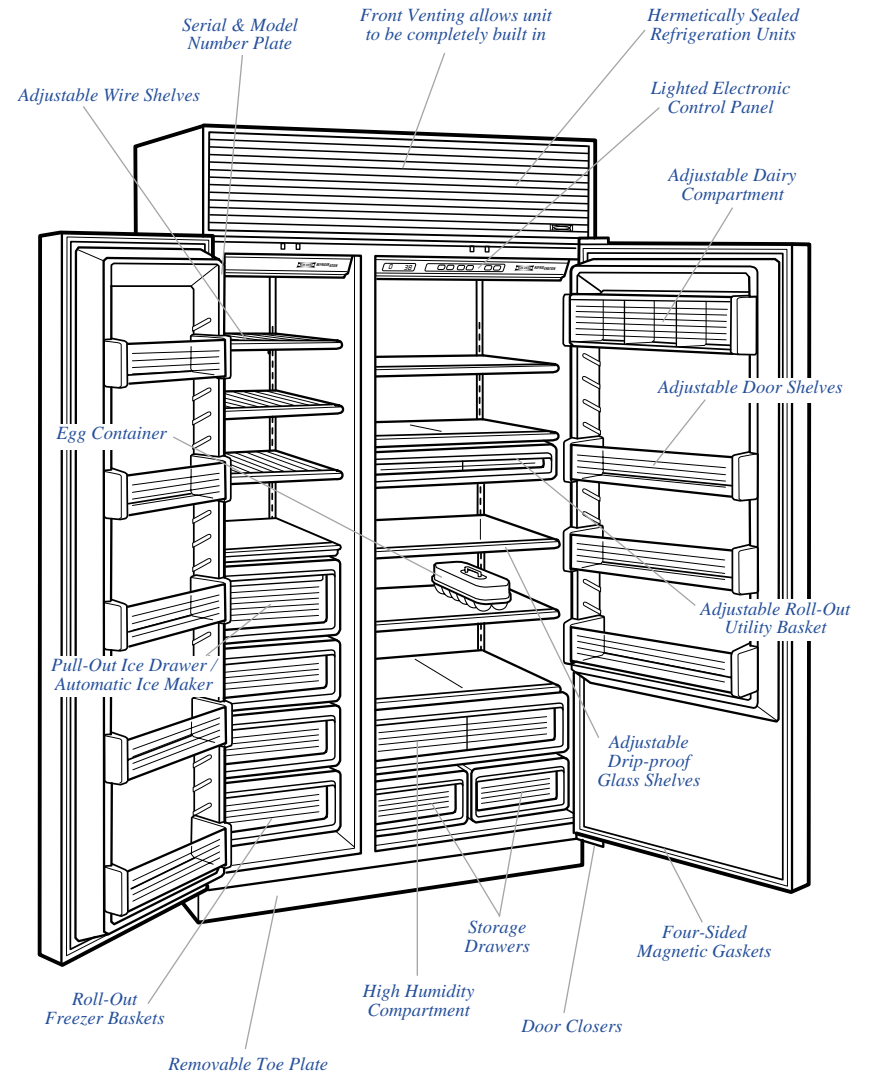

Model 680

Ice and Water Through the Door

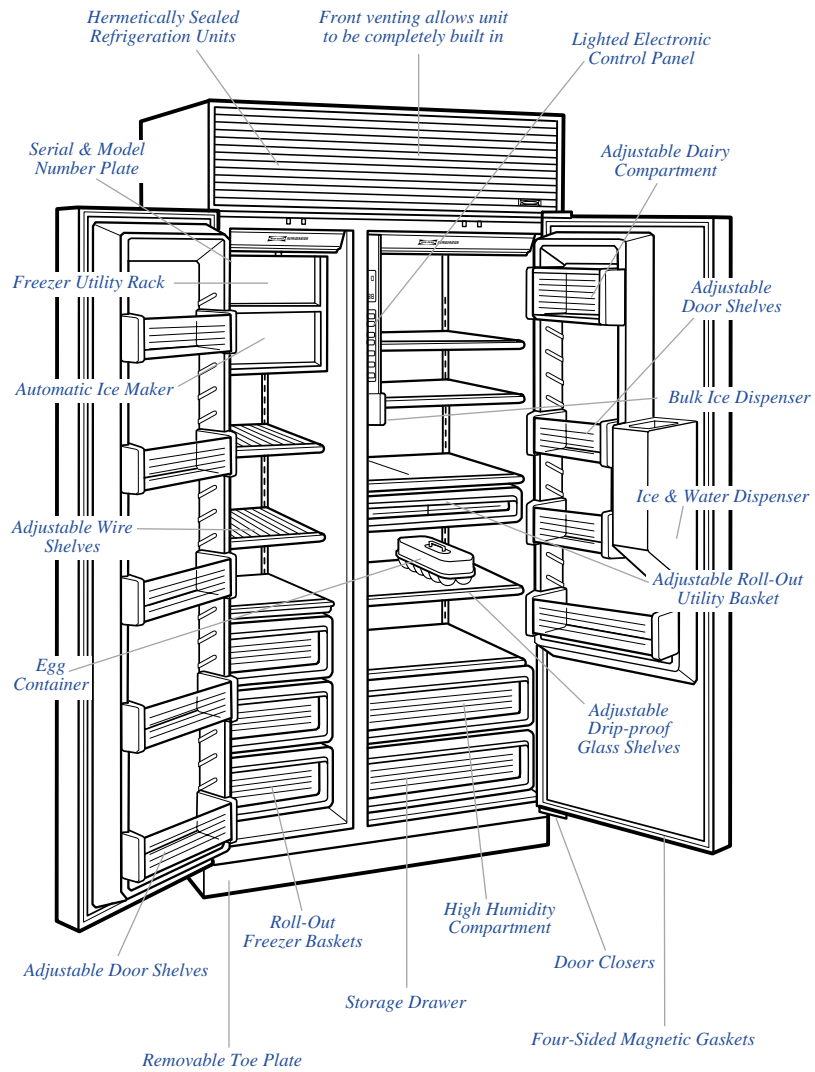

Model 690

Ice and Water Through the Door

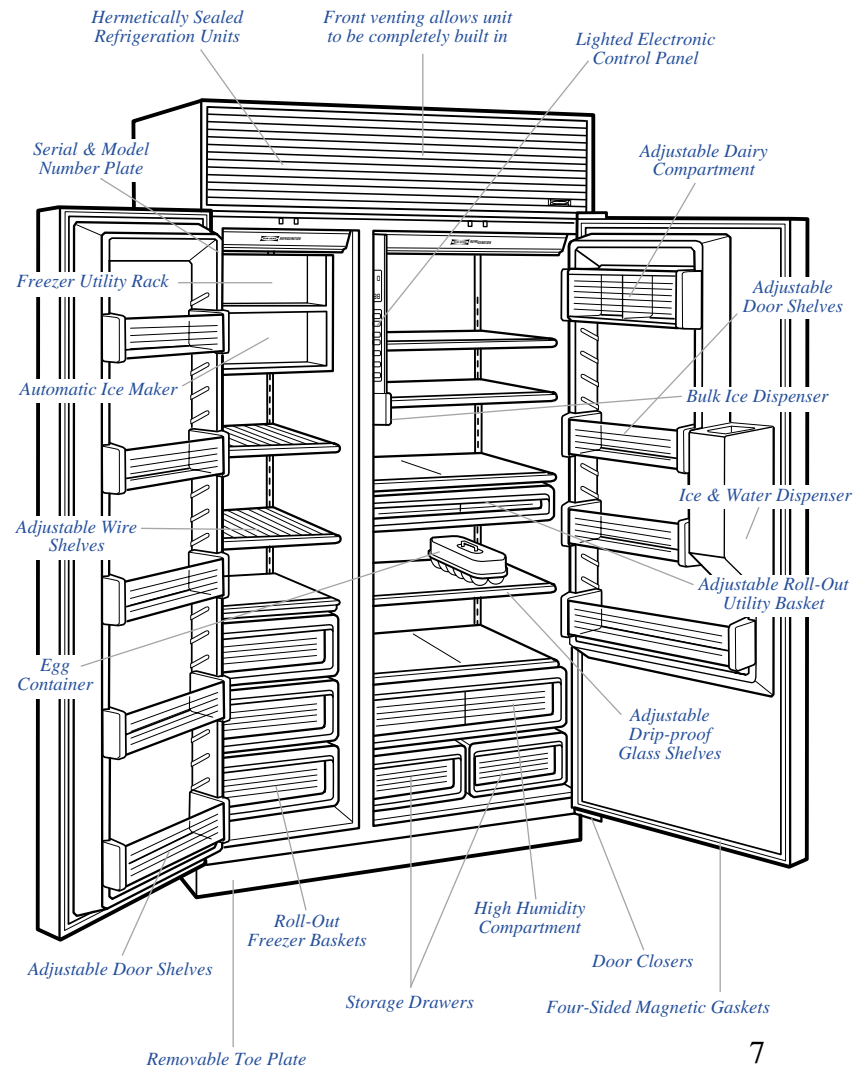

600 SERIES MODELS

Model 561 *Combination Unit*

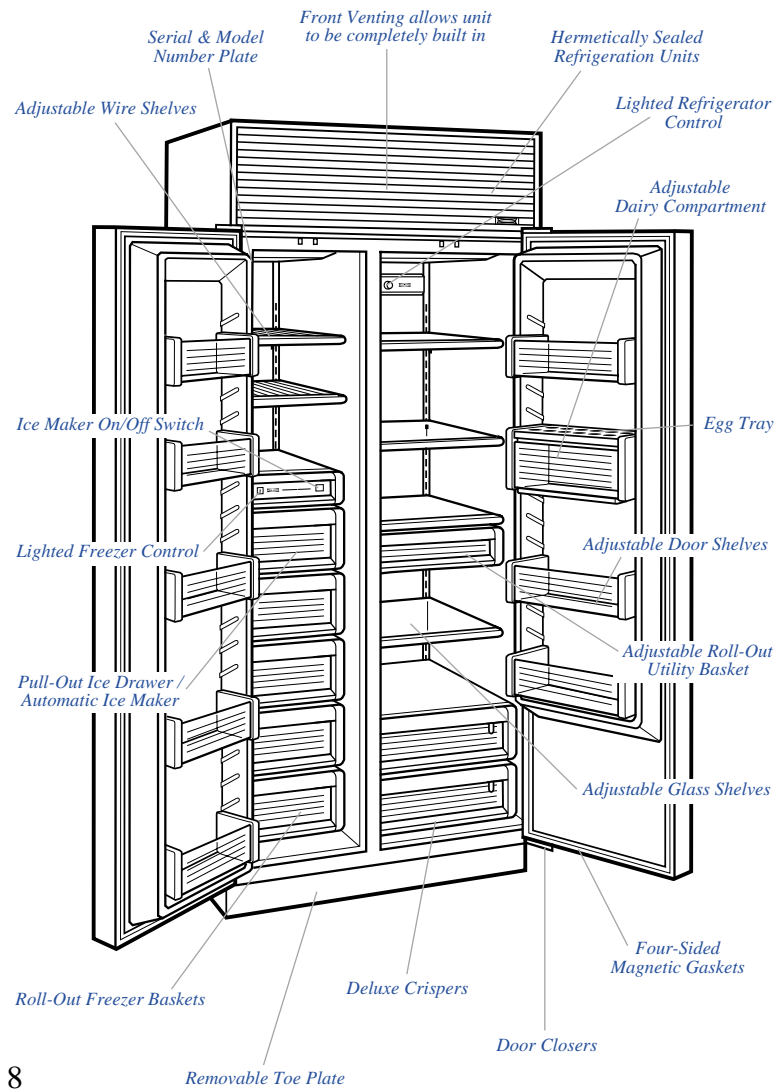

FEATURES OF THE 600 SERIES

Sub-Zero's Dual Refrigeration Assures Maximum Freshness...

The 600 Series continues the Sub-Zero tradition of superior quality and reliability. Sub-Zero pioneered the development of our exclusive dual refrigeration system, giving you optimum fresh and freezer food storage in ideal self-contained compartments. Both refrigerator and freezer maintain accurate, consistent temperatures. Dual refrigeration keeps your food fresh longer than any other system available.

With dual refrigeration, the freezer maintains a constant temperature within one degree of the temperature you set within our range of -5°F to +5°F, without unwanted moisture and odor from the refrigerator. Similarly, you can adjust the refrigerator temperature within a range of 34°F to 45°F, at humidity levels tailored to your home.

The dual refrigeration system also means there is no transfer of fresh food odors to frozen food or ice. And the Sub-Zero 600 Series system does not freeze the moisture out of the air in the fresh food compartment.

Sub-Zero dual refrigeration is also more energy efficient than old-fashioned single refrigeration systems. When the refrigerator is used frequently during the day it does not require the freezer to circulate its very cold, dry air to the refrigerator. Instead, the refrigerator uses moist air to keep fresh foods fresh and energy use minimal.

Sub-Zero's design, beauty and quality are reflected in the broad range of standard features that put Sub-Zero in a class by itself. Whether your customer prefers stainless steel, traditional framed or overlay design, Sub-Zero's 600 Series has the most design options to complement your installation. The custom-design appearance of the Sub-Zero 600 Series gives it unique consumer appeal and gives you options no other line offers.

In addition, Sub-Zero units give you all these features:

- New overlay models blend seamlessly into your overall room design and complement surrounding cabinetry.
- Stainless steel models feature new wrapped doors, one-inch diameter stainless steel handles and stainless steel grille designed specifically to enhance the aesthetics of the professional look of kitchens today.
- Classic framed models – the look that made Sub-Zero famous – now feature an improved grille design, new handle design and elegant new hinges.

FEATURES OF THE 600 SERIES

- All 600 Series combination units have the exclusive Sub-Zero dual refrigeration system, which ensures the freshest food and energy efficiency at the same time. You have precise independent control of the refrigerator and freezer compartments.
- High-humidity compartment is large and deep with smooth sides for easy cleaning. The compartment features removable dividers, with the exception of Models 642 and 680.
- Controls are up front and easy to use. They give you digital readings for quick, easy-to-read reference. Up-front controls also keep you informed about the operation of the unit on a continuous basis.
- Bright lighting spreads even illumination throughout the compartment and conceals the source.
- Sub-Zero's added a microprocessor to give you better control, automatic defrosting that senses, then adapts to your use patterns, and a vacuum condenser indicator light.
- A one-gallon storage door shelf is available as an option at no charge on all 600 Series models except for Models 601F and 561. It affords convenient door storage for those large containers.
- Cantilevered shelves make repositioning quick and easy. They're easy to clean and drip-proof. They are steel reinforced to provide durability and reliability.
- Dairy compartment is adjustable, with easy, one-door access, compartment dividers and a clean design. The dairy shelf is magnetically sealed to maintain freshness.
- Ice maker provides high-quality, crescent-shaped ice that won't stick to the side of the glass.
- Shallow-depth design means access is easy to any area of the refrigerator.
- In-door shelves are all adjustable for complete flexibility.
- Magnetic gaskets around all doors give extra tight seals.
- Our solid-core doors improve insulation and structural integrity.
- Solid, adjustable toe plate gives a true built-in look, and conforms to American Institute of Architects standards.

USING YOUR SUB-ZERO

The Electronic Control System

The Electronic Control System of your Sub-Zero 600 series unit monitors and accurately displays compartment temperatures within one degree of your pre-set temperature. It also monitors operation of the unit and lets you know if there's a problem. You'll find the Control Center located in the refrigerator section of all models except Model 601F, where it is in the freezer compartment.

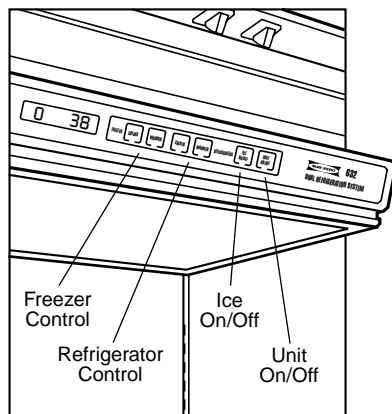

Electronic control center

Temperature Control

Your new refrigerator/freezer was thoroughly inspected and tested before it was shipped from the Sub-Zero factory. Temperatures are preset at 38°F in the refrigerator section and 0°F in the freezer section.

There are two sets of WARMER and COLDER key pads, one for the refrigerator and the other for the freezer. To adjust the temperature in either compartment, depress the WARMER or COLDER keys on the Control Center.

NOTE: The temperature ranges are -5°F to +5°F in the freezer section, and 34°F to 45°F in the refrigerator section. It is normal for temperatures to fluctuate slightly, depending on external influences such as: an open door, the degree of humidity and room temperature.

NOTE: Always allow 24 hours for the refrigerator to reach the temperature you set.

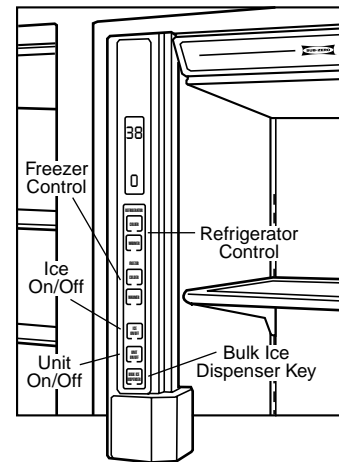

Models 680 & 690 control center

Power On/Off

All 600 Series units feature a UNIT ON/OFF key on the Control Center. This key will turn off all electrical power. When the power is off, the OFF indicator light will be visible on the display panel. This UNIT ON/OFF key means you don't have to shut off power at the circuit breaker or wall receptacle. The key can be used during service or extended vacations.

Ice Maker On/Off

Your 600 Series unit features an ICE ON/OFF key on the Control Center. This key switches the power to the ice maker system on or off. When the ice maker system is on, the ICE indicator light will be illuminated on the display panel. Use the ICE ON/OFF key to shut down the ice maker system during extended vacations.

USING YOUR SUB-ZERO

Refrigerator Storage

Visual Display During Servicing or Condenser Cleaning

The Control Center monitors compartment and component temperatures as well as the ice maker system. If there is a temperature or ice maker problem, you'll be alerted by a flashing SERVICE indicator light. If the condenser needs cleaning, you'll be alerted by a flashing VACUUM CONDENSER indicator light. These indicator lights will flash until corrections are made and the power is turned off, then back on.

High Humidity Drawer

To remove your high humidity drawer, pull open until the drawer stops. Now raise the front of the drawer and pull it out. To reinstall the drawer, insert it into the tracks with the front end raised. Some units also have other storage drawers, which can be removed in a similar manner.

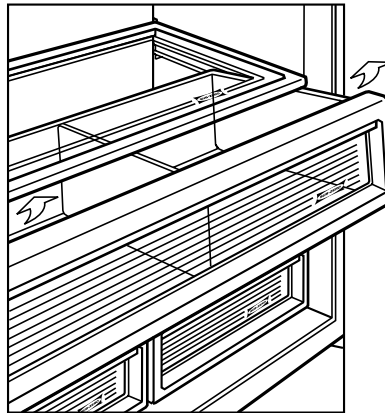

High humidity drawer

Adjustable Shelves

Be sure to read and understand the following instructions before removing or adjusting shelves. The process is relatively simple if you understand the steps involved in advance. To remove or adjust shelves, first tilt the shelf up at the front, then lift it up and out of the tracks on the rear wall of the refrigerator. If the door opens only to 90°, lift and tilt the right end of the shelf up in order to clear the door shelves. Always be careful in handling glass shelves to prevent breaking or scratching the interior.

To replace a shelf, insert it in the tracks at the rear of the refrigerator with the front of the shelf raised slightly. As you push the shelf in, lower the front of the shelf until it locks into position.

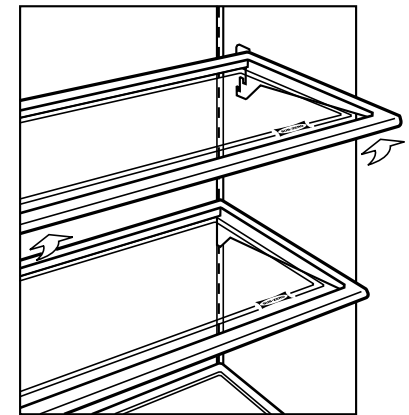

Adjustable Glass Shelves

Utility Basket

The utility basket rolls in and out so that you can get to small containers and food items easily. To remove the basket, pull it out, lift up on the front, then out. If the door opens only to 90°, you'll need to remove the entire basket and shelf as one unit. To do this, place one hand palm up under the roll out utility basket and lift it out of the support track. Tilt the right end upward and remove it, clearing the door shelves. To replace the basket, insert the roller into its tracks with the front of the basket raised, and push in.

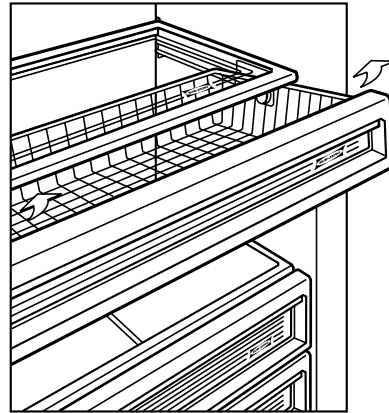

Refrigerator utility basket

Door Shelves and Dairy Compartment

The door shelves and dairy compartment are adjustable within the guides of the door liner. To remove shelves or dairy compartment, lift straight up and out from the bottom. To reinstall the shelves, push them down into the guides.

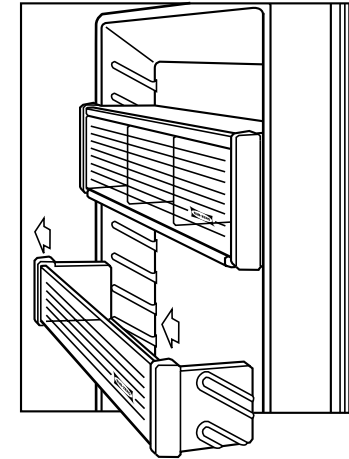

Door shelf and dairy compartment

IMPORTANT NOTE: *The optional one-gallon storage door shelf is adjustable. However, it is recommended that this shelf be kept at the bottom of the door liner, allowing room for the door to close properly. Be careful not to store food close to the edge of the bottom glass shelf as this may stop your door from closing tightly.*

USING YOUR SUB-ZERO

Freezer Storage

Freezer Drawer Removal Models 611 and 650

For safety, the freezer drawer stops before coming all the way out of the unit. To remove it, lift up evenly on each side of the drawer while holding the top basket in place, and pull out. The drawer and basket will come out together.

IMPORTANT NOTE:

Be sure to unload the drawer before removing it.

CAUTION

As you remove the drawer, be very careful to keep your feet clear.

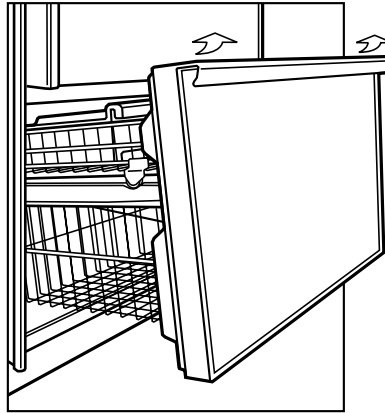

Models 611 & 650 freezer drawer

Freezer Basket Removal Models 601F, 642, and 632

First, unload the freezer basket. To remove the basket, pull it out until it stops. Raise the front of the basket and pull it out. If the door is limited to a 90° opening, pivot the basket away from the door and tilt it up sharply as soon as the rollers leave the tracks.

If the basket sticks during removal, lift it up to disengage the rollers. To reinstall the basket, reverse the procedure.

IMPORTANT NOTE:

Unload the freezer baskets before removing.

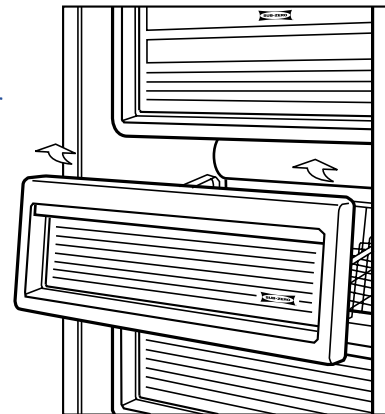

Freezer basket removal

Ice Bucket Removal Models 642 and 632

To remove the ice bucket, pull it out until it stops, and lift the back of the bucket up to clear the carrier assembly. Next, lift the ice bucket out. If the door is limited to a 90° opening, repeat the procedure, but when lifting the ice bucket out, pivot the right side of the bucket toward you and out. This will allow the ice bucket to clear the door.

Ice Bucket Removal Models 601F, 611 and 650

To remove the ice bucket, pull the freezer drawer or basket out until it stops and lift the ice bucket out.

Freezer Utility Rack Models 680 and 690

The freezer utility rack is specifically designed to accommodate and hold freezer juice containers. To remove the rack, lift up and pull out at the bottom with one hand, then support the top with your other hand.

Ice Bucket Removal Models 680 and 690

To remove the ice bucket of Model 680 or 690, you must first remove the freezer utility rack. Then, lift up on the ice bucket handle and pull out, supporting the bottom of the ice bucket with one hand.

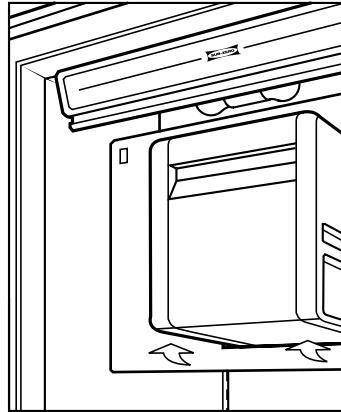

Models 680 & 690 ice bucket

Ice Maker Operation

The ice maker in your Sub-Zero freezer is fully automatic and has been tested at the factory. To start making ice, activate the ICE ON/OFF key on the Control Center. On Models 601F, 611 and 650, the ice maker system will shut off if the ice bucket is not in place.

Ice Production

The ice maker is designed to produce enough ice for normal family use. The timing of ice making cycles will vary depending on load conditions, door openings and room temperature. On average, you can expect a cycle of ice every two hours.

If ice is not used regularly it tends to fuse together. To avoid this, empty and replace the ice in the container monthly.

USING YOUR SUB-ZERO

Models 680 and 690 Ice and Water Through the Door

Ice and Water Dispenser

Your Model 680 or 690 automatic ice and water dispenser gives you both ice and chilled water without having to open doors. To operate the ice dispenser, hold the ice dispenser key down until you've got the ice you need. After initial ice maker start-up, discard the first few batches of ice – they may be discolored by the new system plumbing.

The ice dispenser will deliver ice when you 1) insert a glass into the glasswell and push the ice dispenser key; or 2) open the refrigerator door and place an ice container underneath the ice dispenser chute, then press the bulk ice dispenser key on the chute housing. See *Models 680 & 690 control center*, page 11.

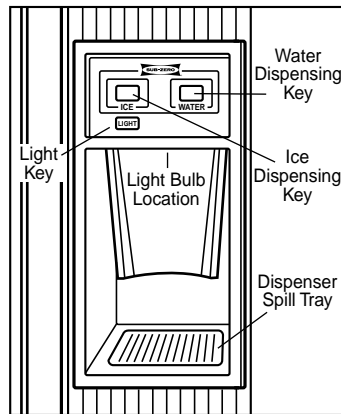

Models 680 & 690 glasswell

CAUTION

Use a sturdy glass to catch ice crescents. Fragile glasses can break. Also, limit ice dispenser operation to eight minutes or less, to avoid damaging the equipment.

Ice Dispenser Operating Tips

- If there's no ice, check to make sure the ice maker system is turned on and that the ICE indicator light is on.
- Make sure there's a supply of ice in the ice bucket. See *Ice Bucket Removal*, page 15.
- Make sure the ice bucket is all the way in and engaging the auger motor at the back of the bucket. If the ice bucket is not all the way back, push on the bucket and ice dispenser switch at the same time.
- Make sure the freezer utility rack is properly installed, to make sure the ice bucket is properly positioned. See *Freezer Utility Rack*, page 15.
- Press the ice dispenser key. If you do not hear auger motor noise, wait five minutes, then try again. If you do not hear auger noise after the second try, call your local Factory Authorized Service Center.
- If the ice dispenser is not used for a long period, the ice may fuse together. To avoid this, empty the ice bucket periodically.

To operate the water dispenser, press the water dispenser key pad continuously until your container is filled. The key is located on the refrigerator door glasswell. The first time you use the water dispenser, purge the water system and storage tank for three minutes. This will clear out any air in the system, along with foreign material in the new plumbing connection.

Initially, for water to dispense properly, the water dispense key pad must be depressed and held until water flows from the dispenser. You may have to hold the key for 60 seconds for the water to fill the internal reservoir.

IMPORTANT NOTE:

The chilled water container is mounted inside the refrigerator section. It will take several hours to chill the water to the refrigerator temperature during the original fill or after a lot of water is used.

▲ CAUTION

Limit water dispenser operation to eight minutes or less, to avoid damaging the equipment.

Light Bulb and Light Key for Dispenser

The door dispenser LIGHT key is located on the bottom left corner of the Control Center, in the ice and water dispenser glasswell. Press the LIGHT key to turn the dispenser light on and off. In the OFF mode, the light will turn on when either the ICE or WATER key is pressed, and remain on for five seconds after either key is released. The light bulb can be easily replaced with a seven watt appliance bulb.

▲ CAUTION

Shut off power at the Control Panel before changing bulbs.

Dispenser Spill Tray

A spill tray at the bottom of the ice and water dispenser will catch and evaporate small spills. Because there is no drain in this area, do not pour water into the spill tray. To clean the area, remove the spill tray grid by pressing the front left corner of the grid and lifting it out.

USING YOUR SUB-ZERO

Operations

Door Closing Models 601R, 601F, 642, 632, 680 and 690

Your refrigerator and freezer doors have spring-loaded closure mechanisms. As the doors are closed, the door closure engages to help close and seal the doors. A 90° door stop is available through your Sub-Zero dealer.

Door and Drawer Closing Models 611 and 650

Your refrigerator door has a door closing cam to help in closing the door. With the door opened to about 120° the cam will hold in the open position if the door is stopped. As you close the door, the cam will take over at about 15° to help close the door.

Your freezer drawer has a self-closing mechanism. The incline, built into roller assemblies on the drawer, uses gravity to assist in closing the drawer.

If your Series 600 unit is positioned in a corner, you may want to install an optional door stop kit which limits door opening to 90°. This door stop is provided with each Model 611 and 650, and is shipped in a plastic bag in the grille area.

Condenser Fan Motor Operation

All 600 Series models have a fan behind the grille to cool the compressor area. This fan runs with either compressor.

Automatic Defrost

For convenience, your Sub-Zero unit is equipped with an automatic defrost system. The refrigerator section will defrost during each off cycle of the refrigerator compressor. The freezer section is controlled by an energy-saving Adaptive Defrost system, which defrosts as needed.

Sounds

You may hear some noises in the normal operation of the unit. Surrounding acoustics like walls, floors and cabinets may affect the sound of your unit. For example, a gurgling or running water sound is probably refrigerant circulating through the tubing. In Models 680 and 690, the ice dispenser valve inside the refrigerator door snaps closed five seconds after either the water or ice dispenser key is released.

During the ice maker cycle you may hear the sound of ice dropping into the container or the solenoid valve operating while refilling the ice maker with water. During the freezer defrost you may hear crackling and/or sizzling as the heat from the defrost element clears the frost from the freezer coil and water runs into the water pan.

While the compressors are in operation you may hear a slight hum. During the startup and shutdown of the compressor, you may feel vibration for a few seconds.

CARING FOR YOUR SUB-ZERO

Cleaning

Exterior Cleaning

If you have purchased a stainless steel model, use a soft, non-abrasive stainless steel cleaner you may purchase locally to wipe down the exterior. If you have difficulty finding a good cleaner, try Signature Polish from Signature Limited Laboratory, P.O. Box 13436, Dayton, Ohio 45413-0436; 877-376-5474.

⚠ CAUTION

Before cleaning your unit, shut the electricity off at the Control Center. When you clean the condenser, wear gloves to avoid injury.

Clean the condenser area every three to six months. In all 600 Series models, the condenser is located behind the grille. First, remove the grille. Use a soft bristle brush and vacuum to remove dust and lint from the condenser (radiator).

⚠ CAUTION

Failure to clean the condenser could result in temperature loss or mechanical failure or damage.

To remove a standard louvered grille, first remove the grille screws. Tilt the grille forward at the top and release the springs from behind the grille, then lift it off.

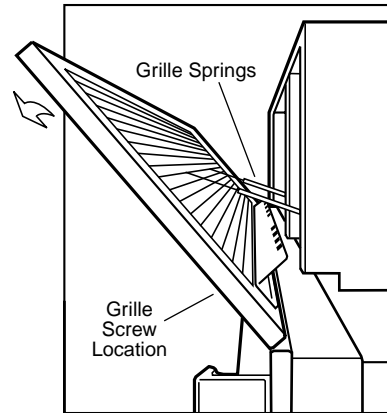

Louvered grille removal

To remove the grille for Models 601R and 601F, remove the two black screws in the lowest louver in the grille. Tilt the bottom of the grille out and away. It will release from the top of the grille.

To remove a panel grille, lift up, then pull out at the bottom and down to release from its mounting bracket.

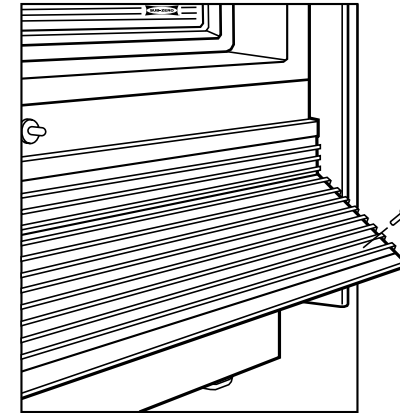

Models 601R & 601F grille removal

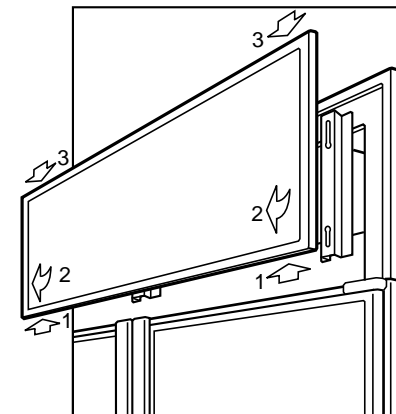

Panel grille removal

CARING FOR YOUR SUB-ZERO

Lighting Information

Interior Cleaning

To clean interior surfaces and removable parts, wash with a mild solution of soap and lukewarm water with a little baking soda. Do not use vinegar. Rinse and dry thoroughly. Avoid getting water on lights, control display panel and Control Center.

CAUTION

Do not submerge or pour hot water over cold glass shelves.

To clean the glasswell of Model 680 or 690, use a mild solution of soap and water with a little baking soda. Wipe up spills after removing the dispenser spill grid.

Cleaning the Ice Chute Models 680 and 690

Ice crescents may occasionally become lodged in the ice chute of the Model 680 or 690. The ice chute is a clear plastic housing that directs ice from the freezer ice bucket to the door ice dispenser. To remove these obstructions, hold the bottom of the side panel and push rearward, then pull out. Once the panel is removed, the clear plastic ice chute and any obstructions will be visible.

To remove the side cover of the ice chute, press the two side locking tabs, then pull up and out. To reinstall, make sure the bottom section of the ice chute is installed first. Then fit the outside front cover lip inside the stationary portion. Finally, push the two assemblies together and close the self-locking tabs.

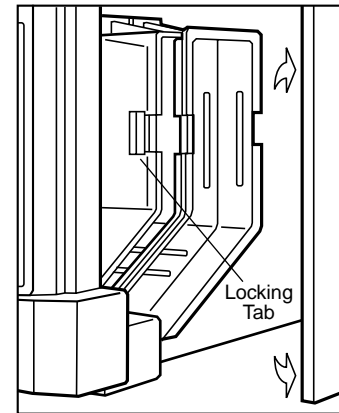

Models 680 & 690 ice chute

IMPORTANT NOTE: *When the refrigerator or freezer doors are left open for a long time, the lights may go off. This protects the internal parts from overheating. To reset the light system, close the door for 15 to 30 minutes.*

Your Sub-Zero unit contains standard 40 watt appliance bulbs in all compartments.

You'll need to remove the light shield in the top of the refrigerator or freezer to replace the bulbs. Place your hands under the light shield and release the two clips on the back of the light shield, then lift up and slide back slowly until the key slots on the side of the light shield drop past the mounting studs in the side walls. Then remove the shield. The bulbs are now accessible.

Vacation Time

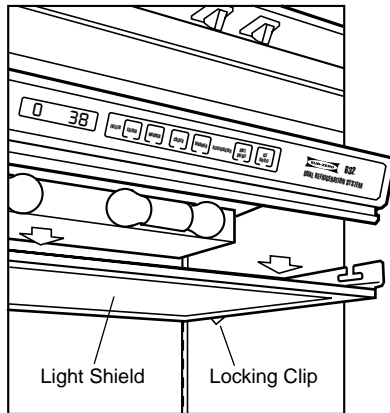

Light shield removal

⚠ CAUTION

Always shut off the power to the unit and wear gloves when replacing light bulbs.

Freezer basket lighting is located below the ice maker and mounted on the back wall of the freezer. To remove the light shield, gently compress the shield to release the top, then the bottom. The bulb is now accessible. To reinstall the shield, put the bottom in place first, then compress and insert the top.

Freezer lighting for Models 611 and 650 is in the top of the freezer, mounted to the front of the evaporator cover. The bulbs are accessible by opening the freezer drawer and unscrewing the bulb from the top front of the freezer.

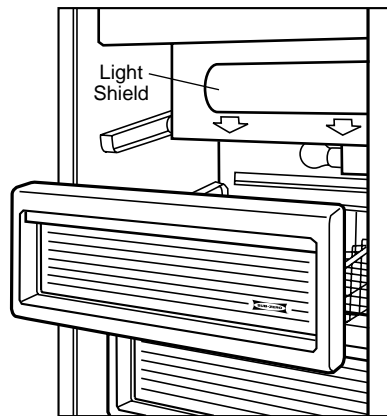

Freezer basket lighting

Freezer lighting for Models 680 and 690 is accessible above the ice bucket once the freezer utility rack has been removed. See *Models 680 & 690 ice bucket*, page 15.

If you're going away for an extended vacation, shut off power to the unit. Empty the unit and block the doors open slightly. A one-inch space will let fresh air in to keep the interior dry and fresh smelling.

For short vacations, remove all perishable items. Shut off the ice maker system and dump the unused ice out of the ice bucket. Don't change the settings of your controls.

If the unit is put into service on a temporary basis and later shut off, block the doors open to allow fresh air to circulate inside the compartment. Be sure to shut off power to the unit.

⚠ CAUTION

Moisture buildup during even the shortest amount of running time could attack the metal.

If your religious observances require turning off the lights and ice maker, use the Control Panel located at the top, front of your unit. While the unit is "on" press the UNIT ON/OFF key so that OFF is visible on the LCD panel. Your unit will be off. Then press and hold the UNIT ON/OFF key for 10 seconds. This will turn the unit back on and will disable the lights and ice maker. To return the unit to normal operating conditions, press and release the UNIT ON/OFF key. See *Electronic control center*, page 11.

TROUBLESHOOTING GUIDE

If your refrigerator or freezer is not operating properly, use the following guide before calling your Sub-Zero Factory Authorized Service Agency or dealer. The guide will save you time and trouble, and may avoid the expense of a service call.

The refrigerator/freezer isn't running

- Is there electrical power to the unit?
- Is your home circuit breaker or fuse off?
- Is your refrigerator/freezer control on?
- Is your condenser area clean?
- Has either door been left open? (Be sure that food is not obstructing proper door closing, particularly in the area of the optional one-gallon storage door shelf).
- If the unit is still not running, it may be in defrost.
- Wait 30 minutes and try to restart again.

The refrigerator/freezer is warmer than usual

- Is your control set properly?
- Is your condenser area clean?
- Has the door been open for a long time?
- Have you recently added a large amount of food?

The refrigerator/freezer runs for long periods of time

- Is condenser area clean?
- On hot days and in warm room temperatures the motor runs longer.
- Have the doors been open for a long time?
- Have you recently added a large amount of food?
- Has either door been left open? (Be sure that food is not obstructing proper door closing, particularly in the area of the optional one-gallon storage door shelf).
- These may be normal operating sounds related to refrigerant circulation, ice maker operation, defrost cycling or compressor operation.

The refrigerator/freezer is frosted up

- Have doors been left open?
- Are doors closing and sealing properly? (Contact your dealer if the door is not adjusted properly. NOTE: When opening the freezer drawer you may notice side to side motion in the drawer. This motion is normal with the tolerance built-in to the drawer slides. When the drawer is closed it will automatically adjust and close with the proper alignment.)

You hear unusual noises

- These may be normal operating sounds related to refrigerant circulation, ice maker operation, defrost cycling or compressor operation.

Condensation forms inside the unit

- This is normal during high humidity and frequent door openings.
- Are doors closing and sealing properly?

Condensation forms on the outside of the unit

- During periods of high humidity some condensation might appear on outside surfaces. The condensation will disappear when the humidity drops. Meanwhile, be sure doors are closing and sealing properly. If condensation persists, contact your Sub-Zero Factory Authorized Service Center.

The outside of the freezer compartment heats up

- Clean the condenser.

There's no ice

- Is the ice bucket in position?
- Is the ice maker turned on?

There's an odor inside the unit

- Clean the unit thoroughly.
- Cover all food tightly.

The light bulb needs to be replaced

▲ WARNING

Turn off the electricity at the Control Center and wear gloves to protect against broken glass.

You hear occasional buzzing

- Is water supply connected to ice maker and turned on?

You need product information

- Call 800-222-7820 for information on planning, installation or product information.

You need product service

- Check the model and serial number of your unit located on the plate at the top of the side frame, inside the unit, close to the hinge. Then call your Sub-Zero Factory Authorized Service Center. For the location of the Service Center in your area, contact your dealer or Sub-Zero Freezer Co., Service Department, P.O. Box 44130, Madison, WI 53744-4130, call 800-222-7820 or e-mail us at customerservice@subzero.com.

KEEPING FOOD AT ITS BEST

Keeping Food Fresh

Your Sub-Zero unit is the most advanced refrigeration system available to keep food fresh and safe to eat. But the quality and safety of your food also depends on how you handle it.

The information in this section gives you the most up-to-date handling and storage recommendations to help you keep food at its best. If you have specific questions that are not addressed here, contact your University or County Extension Service, or your local utility company.

Most food inevitably deteriorates over time. From the very beginning until it is consumed, food undergoes changes. Microorganisms get into food, multiply and cause spoiling.

Enzymes that occur naturally in food continue the ripening process even after the food is harvested. Improper temperatures cause food to deteriorate faster. Changes in humidity cause wilting and shriveling that can lead to spoiling.

Sub-Zero's exclusive dual refrigeration system is specifically designed to combat these changes, and keep your food fresh longer. Both refrigerator and freezer maintain accurate, consistent temperatures and proper humidity levels tailored to your home. Dual refrigeration eliminates transfer of fresh food odors to frozen food or ice, and does not freeze the moisture out of the air in the fresh food compartment.

In addition, good handling practices can minimize the rate of changes in food...

- Follow the recommended storage times and temperatures in this guide. Your Sub-Zero unit helps to slow the ripening process by tailoring temperatures to each compartment as needed.
- Use specially designed compartments for dairy foods, deli foods and fresh produce. These compartments maintain temperature and humidity levels that keep specific food groups fresh.
- Rotate food in refrigeration units, using a "first-in, first-out" system.

- When food does spoil, it's usually obvious. It becomes moldy, has an off-odor, looks rotten or discolored. But there are times when spoiling may not be so apparent. If you think a food has been stored too long, discard it. Don't taste it to check if it's okay.
- While the bacteria that cause food spoilage will not cause food-borne illness or food poisoning, taste tests are not a good idea.

Keeping Food Safe to Eat

Most food borne illness is caused by bacteria such as staphylococcus, salmonella, e coli and botulism. These bacteria grow rapidly at temperatures between 45°F and 140°F, a range that's called the Danger Zone. Never leave food in the danger zone for more than two hours. When the bacteria have multiplied to the millions in warm temperatures, they cause illness. Some bacteria cause flu-like symptoms, while others cause serious illness or even death. Young children, the elderly and people who are already ill are more likely to become sick from food poisoning.

To reduce your risk of food borne illness, use the following techniques to keep your food safe to eat:

When You're Shopping

- Place packages of raw meat, seafood or poultry in plastic bags to keep them from dripping on other foods.
- Shop for meat, seafood and poultry last. Don't leave these foods in a hot car when you've finished shopping. Take along a cooler in hot weather or when you have to travel long distances.
- Check "use by" and "sell by" dates on foods to make sure they're fresh. Use extra care when buying deli food. Buy only the amount you will use in 1-2 days. Discard hot or cold deli food that has been at room temperatures for more than two hours.

When You Store Food

- Monitor temperatures of refrigeration zones on the electronic control panel of your Sub-Zero unit. Keep the refrigerator temperature at 45°F or below, and freezer temperature at 0°F.
- Follow the recommended refrigerator and freezer storage times and temperatures in this guide.
- Store raw meat, poultry and seafood separate from other foods. Keep juices from these packages from dripping on other food.
- Never taste food that looks or smells strange to test its freshness. Discard it.
- For refrigerator storage, leave raw meat, poultry and seafood in its original wrapper unless it is torn. Repeated handling can introduce bacteria to these foods. For freezer storage, use freezer wrap, freezer-quality plastic bags or aluminum foil over the commercial wrap if foods will be stored in the freezer for more than a couple of months. This minimizes dehydration and quality loss.

KEEPING FOOD AT ITS BEST

- Wrap food stored in the refrigerator unit in foil or plastic wrap, or place it in plastic bags or airtight containers to keep it from drying out. Date all packages.
- Wrap food stored in freezer units in freezer wrap, or place it in freezer-quality plastic bags or containers. Single layers of aluminum foil may tear and cause freezer burn.

When You Prepare Food

- Clean everything that comes in contact with food.
- Wash your hands for 20 seconds before and after handling food.
- Sanitize counters, equipment and utensils after handling raw meat, seafood or poultry. Rinse with a dilute chlorine bleach solution, one teaspoon to a quart of water.
- Use clean kitchen towels, sponges and cloths. Replace sponges every few weeks.
- Use disposable plastic gloves if you have an infected cut or burn on your hands.

- Thaw food in the refrigerator or microwave oven, not on the counter. When you thaw food in a microwave oven, cook it immediately.
- Marinate food only in the refrigerator.
- Rinse poultry and seafood in cold water before cooking.
- Avoid cross-contamination in preparing food. Keep raw meat, poultry and seafood and their juices away from other food. For example, don't use the same surface and utensils for preparing raw meat, poultry and seafood that you use for preparing salad ingredients.

- Thoroughly clean your plastic and wooden cutting boards.
- Wash with hot water and soap, and rinse with a diluted chlorine bleach solution of 1 teaspoon to a quart of water.

When You Cook Food

- Don't taste raw or partially cooked meat, poultry, eggs or fish.
- Cook meat to an internal temperature of 165°F or above, poultry to 180°F or above. For cuts more than two inches thick, use a meat thermometer to check the temperature. For thinner cuts, clear juices (not pink) are a sign of doneness.
- If you are cooking frozen meat or poultry that has not been defrosted, increased the cooking time to 1 1/2 times the time required for thawed items.

- Roast meats or poultry in oven temperatures of 325°F or above.
- Cook eggs until the yolk and white are firm, not runny.
- Don't use recipes in which eggs remain raw or partially cooked.
- If your microwave has a temperature probe, use it. Check temperatures of meat and poultry in at least three spots. Rotate foods during microwaving.

When You Have Leftovers

- Refrigerate or freeze cooked leftovers in small, covered containers within 2 hours after cooking. Make sure there is adequate air space around the containers so that food can cool down quickly.
- Remove the stuffing from meat or poultry and store it separately.
- Date packages of leftovers and use within a safe period of time.
- Cover and reheat leftovers thoroughly before serving.
- Bring sauces, soups and gravy to a boil. Heat other foods to 165°F.
- If you think food may be spoiled, discard it. When in doubt, throw it out.

KEEPING FOOD AT ITS BEST

Fresh Food Storage Suggestions

Shelf life of fresh foods varies depending on how fresh it is when you buy it. To keep your food fresher longer, follow the recommended storage tips.

- **Vegetables:** Wash vegetables in cool water and drain. Store in air-tight containers or plastic wrap. Vegetables do well in high-humidity storage.
- **Fruits:** Wash and dry fresh fruits. Store more aromatic fruits in plastic bags. Fruits do well stored in low humidity.
- **Prepackaged Meats:** Store in original packaging. After opening, rewrap tightly in plastic wrap or aluminum foil.

- **Fresh Meats, Fish and Poultry:** Remove store wrappings, then rewrap in plastic wrap, foil or waxed paper and refrigerate immediately.
- **Eggs:** Store eggs unwashed in their carton or a portable egg tray. Use within 2 weeks.
- **Milk, Cream, Cottage Cheese:** Keep carton closed. Store on refrigerator shelf and use within 5 days.
- **Cheese:** Store in original packaging until ready to use. After opening, rewrap tightly in plastic wrap or aluminum foil.
- **Leftovers:** Let cool and cover tightly with plastic wrap or foil. Airtight plastic containers work well to prevent drying out and odor transfer.

Frozen Food Storage Suggestions

- **Freezer Storage:** Wrap foods in material designed for frozen food storage. The wrap must seal out air and moisture. Do not refreeze thawed meats.
- **Ice Cream:** The firmness of the ice cream will depend on its cream content. Higher quality ice creams usually have a higher cream content requiring colder freezer temperatures to maintain their firmness. Soft ice cream is not always an indication of a temperature problem.

A Final Note...

Make sure your refrigerator and freezer doors close freely and completely. Overloading will affect temperatures inside the unit. Do not fill your freezer with large quantities of unfrozen foods expecting them to “fast freeze.” Give the freezer ample time to circulate cold air around unfrozen items before adding additional items.

<i>Meat, Fish, Poultry</i>		Recommended storage temperature in degrees F	Approximate storage life at refrigerator temperatures	Recommended storage time in freezer at 0°F	Comments
Food	Form				
<i>Fresh Fish and Seafood</i>	cod, flounder, haddock, sole bluefish, perch, mackerel, salmon shrimp oysters	32 32 32 32	2 days 2 days 4 days 1 day	6 months 2-3 months 5-9 months 4 months	<i>Freeze in original wrap up to 2 weeks. Use freezer wrap, freezer-quality plastic bags, or aluminum foil over the commercial wrap if foods will be frozen for more than a couple of months.</i>
<i>Fresh Meat</i>	beef steaks, roasts lamb chops, roasts pork and veal chops, roasts variety meats (tongue, liver, etc.)	32-35 32-35 32-35 32-35	3-5 days 3-5 days 3-5 days 1-2 days	6-12 months 6-9 months 4-6 months 3-4 months	<i>Freeze in original wrap up to 2 weeks. Use freezer wrap, freezer-quality plastic bags, or aluminum foil over commercial wrap if foods will be stored in the freezer for more than two months.</i>
<i>Hamburger, Ground and Stew Meats</i>	hamburger, stew meats, ground turkey, veal, pork, lamb, and mixtures	32-35	1-2 days	3-4 months	<i>Freeze in original wrap up to 2 weeks. Use freezer wrap, freezer-quality plastic bags, or aluminum foil over commercial wrap if foods will be frozen for more than a couple of months.</i>
<i>Hotdogs and Lunch Meats</i>	hotdogs, opened package unopened package lunch meats, opened package unopened package	32-35 32-35 32-35 32-35	1 week 2 weeks 3-5 days 2 weeks	in freezer wrap, 1-2 months	<i>Check "sell by" dates. Do not use more than one week after this date.</i>
<i>Bacon and Sausage</i>	bacon sausage (pork, beef, turkey), raw smoked breakfast links, patties hard sausage - pepperoni, jerky sticks	32-35 32-35 32-35 32-35	7 days 1-2 days 7 days 2-3 weeks	1 month 1-2 months 1-2 months 1-2 months	<i>Keep wrapped, store at recommended refrigerator temperatures.</i>
<i>Ham and Corned Beef</i>	corned beef ham, whole ham, half ham, slices	32-35 32-35 32-35 32-35	5-7 days 7 days 3-5 days 3-4 days	1 month 1-2 months 1-2 months 1-2 months	<i>For freezer storage, drain juices.</i>
<i>Fresh Poultry</i>	chicken or turkey, whole chicken or turkey, pieces duck or goose	32-35 32-35 32-35	1-2 days 1-2 days 1-2 days	1 year 9 months 6 months	<i>Freeze in original wrap up to 2 weeks. Use freezer wrap, freezer-quality plastic bags, or aluminum foil over commercial wrap if foods will be stored in the freezer for more than two months.</i>

KEEPING FOOD AT ITS BEST

<i>Fresh Fruits</i>	Recommended storage temperature in degrees F	Approximate storage life at refrigerator temperatures	Recommended storage time in freezer at 0°F	Comments
apples	34-40	3-6 months	See food preservation books/guides for complete instructions on freezing fruits.	<p><i>Wash and dry most fruits, store in crisper compartment. (Do not wash berries and cherries until you are ready to use them, however.)</i></p> <p><i>Fully ripe fruits should be stored in the refrigerator at recommended temperatures, to slow down the ripening process.</i></p> <p><i>Unripe fruits should be left to ripen at room temperature, in a container that allows for air circulation.</i></p> <p><i>To hasten the ripening process, you can place unripe fruit in a paper bag that has holes poked in it. Close the bag and set it on a counter. The fruit will produce ethylene, a gas that initiates the ripening process. Check the bag each day.</i></p> <p><i>Most fruits should be stored in lower humidity.</i></p> <p><i>Discard any fresh fruits that are moldy or have other signs of spoilage, and wipe out the refrigerator compartment.</i></p> <p><i>See page 32 for a list of ethylene sensitive and ethylene producing vegetables and fruits.</i></p> <p><i>✓ indicates fruit that is sensitive to chill injury, a cause of spoilage. Damage may not be apparent until the fruit is returned to a warmer temperature.</i></p>
apricots	34	1-2 weeks		
asian pears	34	5-6 months		
✓avocados	40	2-4 weeks		
blackberries	34	2-3 days		
blood oranges	40-44	3-8 weeks		
blueberries	34	10-18 days		
✓cantaloupe	36-40	10-14 days		
cassavas	34	1-2 months		
cherries, sweet	34	2-4 weeks		
clementines	40	2-4 weeks		
✓cranberries	36-40	2-4 months		
figs, fresh	34	7-10 days		
✓grapefruit	50-60	4-6 weeks		
grapes	34	8-12 weeks		
✓guavas	40-50	2-3 weeks		
honeydew	45-50	3-4 weeks		
kiwifruit	34	4-6 weeks		
kumquats	40	2-4 weeks		
✓lemons	50-55	1-5 months		
✓limes	48-50	3-5 weeks		
lychees	35	3-5 weeks		
✓mangoes	50	2-3 weeks		
nectarines	34	2-4 weeks		
✓oranges	34-48	3-8 weeks		
✓papayas	45-55	1-3 weeks		
peaches	34	2-4 weeks		
pears	34	2-3 weeks		
persimmons	34	3-4 months		
✓pineapple	45	2-5 weeks		
plums/prunes	34	2-4 weeks		
✓pomegranates	40	2-3 months		
quinces	34	2-3 months		
raspberries	34	2-3 days		
rhubarb	34	2-3 weeks		
strawberries	34	5-10 days		
tangerines	40	2-4 weeks		
✓watermelon	45-55	2-3 weeks		

Fresh Vegetables		Recommended storage temperature in degrees F	Approximate storage life at refrigerator temperatures	Recommended storage time in freezer at 0°F	Comments
Form					
anise	34-36	2-3 weeks	See food preservation books/guides for complete instructions on freezing vegetables.	<p><i>Wash vegetables in cool water and drain. Store in air-tight container or plastic wrap.</i></p> <p><i>Most vegetables should be stored in higher humidity.</i></p> <p><i>See page 32 for a list of ethylene sensitive and ethylene producing vegetables and fruits.</i></p> <p><i>Discard any fresh vegetables that are moldy or have other signs of spoilage, and wipe out the refrigerator compartment.</i></p> <p><i>For fresh-cut produce, follow storage directions on package.</i></p> <p><i>✓indicates vegetables that are sensitive to chill injury, a cause of spoilage. Damage may not be apparent until the vegetables are returned to a warmer temperature.</i></p>	
artichokes	34	1-2 weeks			
asparagus	34-35	2-3 weeks			
✓beans, green/snap and lima	40-45	10-14 days			
bean sprouts	34	7-9 days			
beets	34	3-5 months			
belgian endive	36-38	2-4 weeks			
bok choy	34	3 weeks			
broccoli	34	1-2 weeks			
brussels sprouts	34	3-5 weeks			
cabbage	34	3-6 months			
carrots	34	1-5 months			
cauliflower	34	3-4 weeks			
celeriac	34	6-8 months			
celery	34	2-4 weeks			
chinese broccoli	34	10-14 days			
chinese cabbage	34	2-3 months			
corn, sweet	34	4-6 days			
✓cucumbers	45-50	1-2 weeks			
daikon	34	4 months			
✓eggplant	45-50	1-2 weeks			
endive/escarole	34	2-3 weeks			
garlic	34	3-6 months			
✓ginger root	55	6 months			
horseradish	34	10-12 months			
jerusalem artichokes	34				
✓jicama	55-65	4-5 months			
kale	34	1-2 months			
kohlrabi	34	10-14 days			
leeks	34	2-3 months			
lettuce	34	2-3 months			
mushrooms	34	2-3 weeks			
✓okra	45-50	1-2 weeks			
onions, bulb	34	1-6 months			
onions, green	34	7-10 days			
parsley	34	1-2 months			
parsnips	34	4-5 months			
peas, pods and shelled	34	7-10 days			
✓peppers, bell	45-50	12-18 days			
peppers, chile	45-50	2-3 weeks			
potatoes	40-50	2-4 months			

KEEPING FOOD AT ITS BEST

<i>More Fresh Vegetables</i>	Recommended storage temperature in degrees F	Approximate storage life at refrigerator temperatures	Recommended storage time in freezer at 0°F	Comments
Form				
✓pumpkins	38-55	3-4 months	See food preservation books/guides for complete instructions on freezing vegetables.	✓ <i>indicates vegetables that are sensitive to chill injury, a cause of spoilage. Damage may not be apparent until the vegetables are returned to a warmer temperature.</i>
radicchio	34	2-3 weeks		
radishes	34	3-4 weeks		
romaine	34	2-3 weeks		
rutabagas	34	4-6 months		
salsify	34	2-4 months		
shallots	34	6 months		
snow peas	34	1-2 weeks		
spinach	34	1-2 weeks		
✓squash, summer	40-50	1-2 weeks		
squash, winter	50-55	3-5 months		
✓sweet potatoes	55-60	4-7 months		
✓tamarillos	37-40	2 months		
✓tomatoes (ripe)	34-40	3-4 weeks		
turnips	34	4-5 months		
water chestnuts	34-36	1-2 months		
watercress	34	2-3 weeks		

Don't store ethylene producers...	with foods that are sensitive to ethylene
apples	unripe bananas
apricots	green beans
avocados	belgian endive
ripening bananas	broccoli
cantaloupe	brussels sprouts
cherimoyas	cabbage
figs	carrots
guavas	cauliflower
honeydew	chard
kiwifruit	cucumbers
mamey sapote	eggplant
mangoes	unripe kiwifruit
mangosteen	leafy greens
nectarines	lettuce
papayas	okra
passion fruit	parsley
peaches	peas
pears	peppers
persimmons	spinach
plantains	squash
plums	sweet potatoes
prunes	watercress
quince	watermelon
tomatoes	

Suggested Food Storage

Food safety ... food quality

The food storage charts on pages 29-32 give you specific information to help you keep food safe and keep it at its best quality. The recommended storage temperatures will help you provide *optimal* storage conditions, to help you keep food at its best quality longer. As a general rule, food that requires refrigeration that is handled properly and kept at temperatures below 45°F will be safe to eat.

Storing food at temperatures below 45°F keeps it out of the Danger Zone.

The storage times for refrigeration will help keep food from spoiling or becoming dangerous to eat. The time limits for frozen foods are to maintain flavor and texture ...if food is kept longer than the recommended time in the freezer, it will still be safe to eat, but the quality won't be as good.

Ethylene

Some fruits and vegetables will produce ethylene, a gas that initiates the ripening process. Ethylene can cause premature ripening in some foods, while in others, it can actually cause damage. To reduce unnecessary spoilage of your produce, do not store ethylene producing fruits and vegetables with those that are sensitive to it.

<i>Eggs and Deli Foods</i>		Recommended storage temperature in degrees F	Approximate storage life at refrigerator temperatures	Recommended storage time in freezer at 0°F	Comments
Food	Form				
<i>Eggs</i>	fresh, in shell	32	3 weeks	don't freeze	Keep fresh eggs refrigerated. Don't eat hard-cooked eggs that have been at room temperature for more than two hours.
	hardcooked	32-35	1 week	don't freeze well	
	liquid pasteurized or egg substitutes-	32-35	3 days	don't freeze	
	opened	32-35	10 days	1 year	
<i>Deli Foods</i>	thinly sliced lunch meats	32-35	1-2 days	these do not freeze well	Check use-by or sell-by dates If you are going to freeze any of these foods, freeze immediately ... not after they have been held in the refrigerator.
	egg, chicken, tuna, ham, macaroni salads	32-35	3-5 days		
	pre-stuffed chops, chicken breasts	32-35	1 day		
	store-prepared convenience meals	32-35	1-2 days		
<i>Milk, Cheese, Dairy Foods</i>					
	butter	32-35	3 months	1 year	Check sell-by dates. Store cheese in original packaging until ready to use. After opening, re-wrap tightly in plastic wrap or aluminum foil. Thaw frozen cheese in the refrigerator to reduce crumbling.
	cheese-cottage or ricotta	32-35	1-2 weeks	4 weeks	
	cream cheese	32-35	2 weeks	6-8 months	
	natural (cheddar, brick, etc.)	32-35	3-6 months		
	process cheese	32-35	3-4 weeks	6-8 months	
	grated Parmesan or Romano	32-35	1 year		
	yogurt	32-35	1 month		
	whole, lowfat or skim milk	32-35	1-2 weeks		
<i>Leftovers, Soups, Stews</i>					
<i>Meat Leftovers</i>	cooked meat and meat dishes	32-35	3-4 days	2-3 months	Refrigerate or freeze leftovers in covered shallow containers within 2 hours after cooking. Reheat leftovers to 165°F.
	gravy and meat broth	32-35	1-2 days	2-3 months	
<i>Leftover Cooked Poultry</i>	fried or plain pieces of chicken	32-35	3-4 days	4 months	Refrigerate or freeze leftovers in covered shallow containers within 2 hours after cooking. Reheat leftovers to 165°F.
	cooked poultry dishes	32-35	3-4 days	4-6 months	
	pieces covered with broth, gravy	32-35	1-2 days	6 months	
	chicken nuggets, patties	32-35	1-2 days	1-3 months	
<i>Soups and stews</i>	vegetable or meat added	32-35	3-4 days	2-3 months	Reheat to at least 165°F before eating.

SERVICE FOR YOUR SUB-ZERO

Service

This Use and Care Guide gives you the tools necessary to preserve food at optimum quality in your Sub-Zero unit. Keep doors and drawers closed as much as possible whenever the unit is operating. If you do need service, have the model and serial number when you call. You'll find these numbers located on the plate at the top of the side frame, inside the unit, close to the hinge. Then call your nearest Sub-Zero Factory Authorized Service Center, your dealer or Sub-Zero Freezer Company, 800-222-7820, write P. O. Box 44130, Madison, WI 53744, or e-mail us at customerservice@subzero.com.

“Sub-Zero Protection Plan”

Full 5 Year Warranty and Limited 6th Through 12th Year Warranty on the Sealed System

Full 2 Year Warranty on Total Product

Full Five Year Warranty

For five years from the date of original installation, your Sub-Zero warranty covers all parts and labor to repair or replace any components that prove to be defective in materials or workmanship in the sealed system. The sealed system consists of the compressor, condenser, evaporator, drier and all connecting tubing.

Full Two Year Warranty

For two years from the date of original installation, your Sub-Zero warranty covers all parts and labor to repair or replace any part of the product which proves to be defective in materials or workmanship.

Limited 6th Through 12th Year Warranty

From the 6th through the 12th year from the date of original installation, your Sub-Zero warranty covers all parts that prove to be defective in materials or workmanship in the sealed system (parts only). The sealed system consists of the compressor, condenser, evaporator, drier and all connecting tubing.

Terms Applicable To Each Warranty

All service provided by Sub-Zero under the above warranty must be performed by authorized Sub-Zero service representatives, unless otherwise specified by Sub-Zero. Service will be provided in the home during the normal business hours. This warranty applies only to products installed for normal residential use. Details regarding a non-residential warranty are available upon request.

The warranty applies only to products installed in any one of the fifty states of the United States, the District of Columbia or the ten provinces of Canada. This warranty does not cover any parts or labor to correct any defect caused by negligence, accident or improper use, maintenance, installation, service or repair, including but not limited to improper removal and reinstallation (whether in the unit or at a remote location) of the condensing unit.

The remedies described above for each warranty are the only ones which Sub-Zero will provide, either under these warranties or under any warranty arising by operation of law. Sub-Zero will not be responsible for any consequential or incidental damages arising from the breach of these warranties or any other warranties, whether express, implied or statutory.

Some states do not allow the exclusion or limitation of incidental or consequential damages, so the above limitation or exclusion may not apply to you. This warranty gives you specific legal rights and you may also have other legal rights which vary from state to state.

To receive parts and/or service and the name of the Sub-Zero authorized service representative nearest you, contact your Sub-Zero dealer, distributor or Sub-Zero Freezer Company, Service Department, P.O. Box 44130, Madison, Wisconsin, 53744-4130, call (800) 222-7820 or e-mail us at customerservice@subzero.com.







Sub-Zero Freezer Company, Inc. 4717 Hammersley Road Madison, Wisconsin 53711 (800) 222-7820 or (608) 271-2233